Owner's Manual

Sealweld® SuperSeal II Pump







By Sealweld Corporation

Technical Specification





Sealweld SuperSeal II Pump

- ❖ One (1) High Pressure Sealant/Lubricant SuperSeal II Pump: 100:1 Ratio with 10,000 psi maximum working pressure: 100 psi air inlet pressure (40CFM)
- ❖ 6 meters supply hose. quick connect 1/2" whip hose, complete with 10,000 psi gauge, 10,000 psi Check Valve
- ❖ Parts Description & Function
- ❖ Detailed Diagrams
- ❖ Heavy Duty Frame
- ❖ Whip Hose

PART DESCRIPTION & FUNCTION

MATERIALS DESCRIPTION	SYMBOL	FUNCTION
		<p>Pumps the required lubricant / Sealant</p>
<p>HIGH PRESSURE ARO MULTI PUMP</p>		
		<p>Regulates the flow of main air input supply</p>
<p>MAIN AIR INPUT SUPPLY REGULATOR</p>		

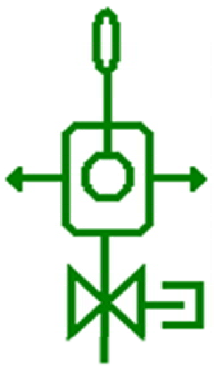

MATERIALS DESCRIPTION	SYMBOL	FUNCTION
		Controls the air supply to the pump (PULL to start the pump and PUSH to stop the pump)
AIR INPUT SUPPLY VALVE		
		Controls the operation (up & down) movement of the piston stem attached to the grease pump
3-WAY CONTROL VALVE WITH REGULATOR		PULL the handle to release the pressure on the grease drum
		
GREASE DRUM RELEASE VALVE		

DIAGRAM

- Pump's main components

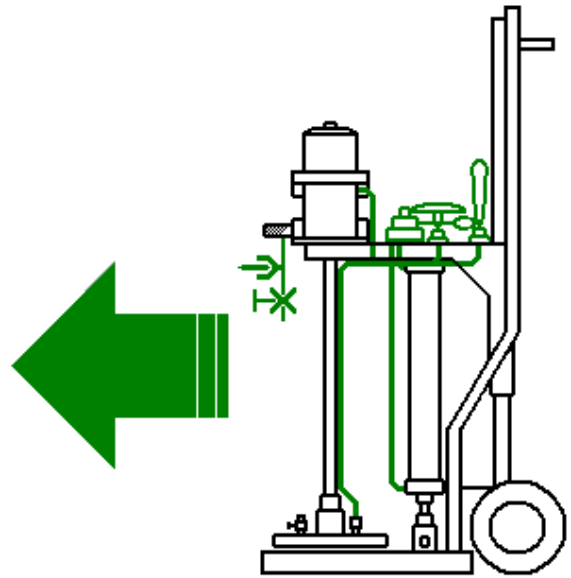
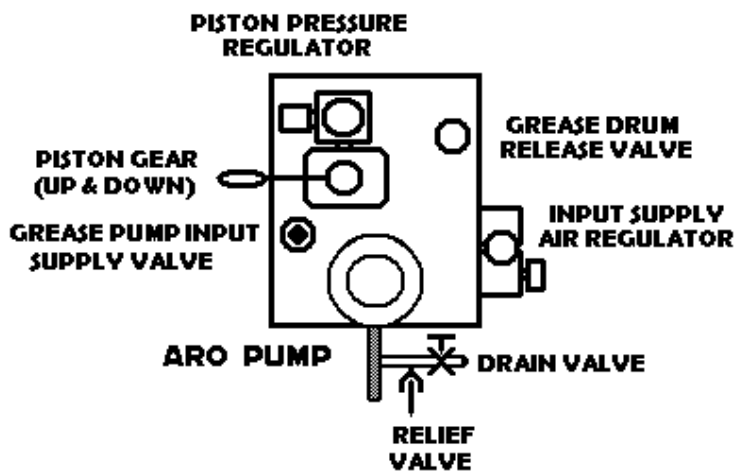

- Pump's main Diagram

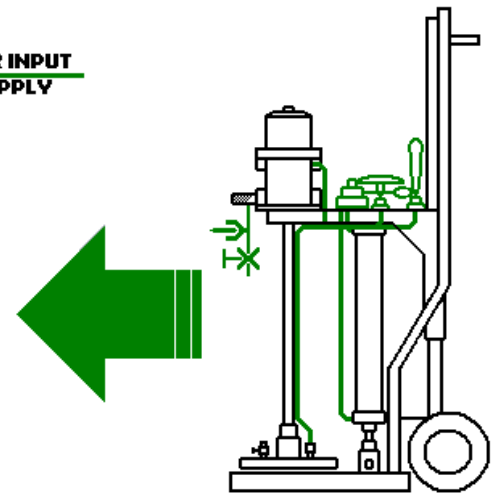
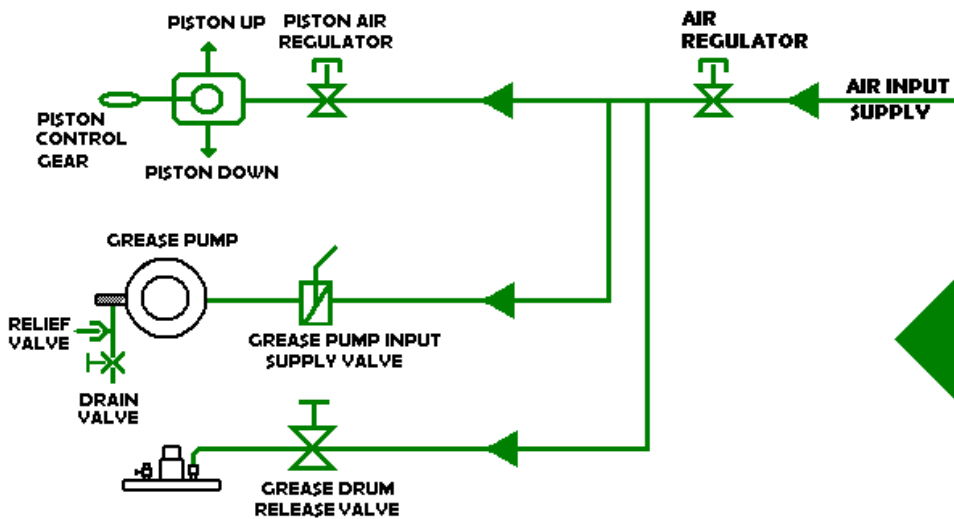

- Pump's Operational Diagram

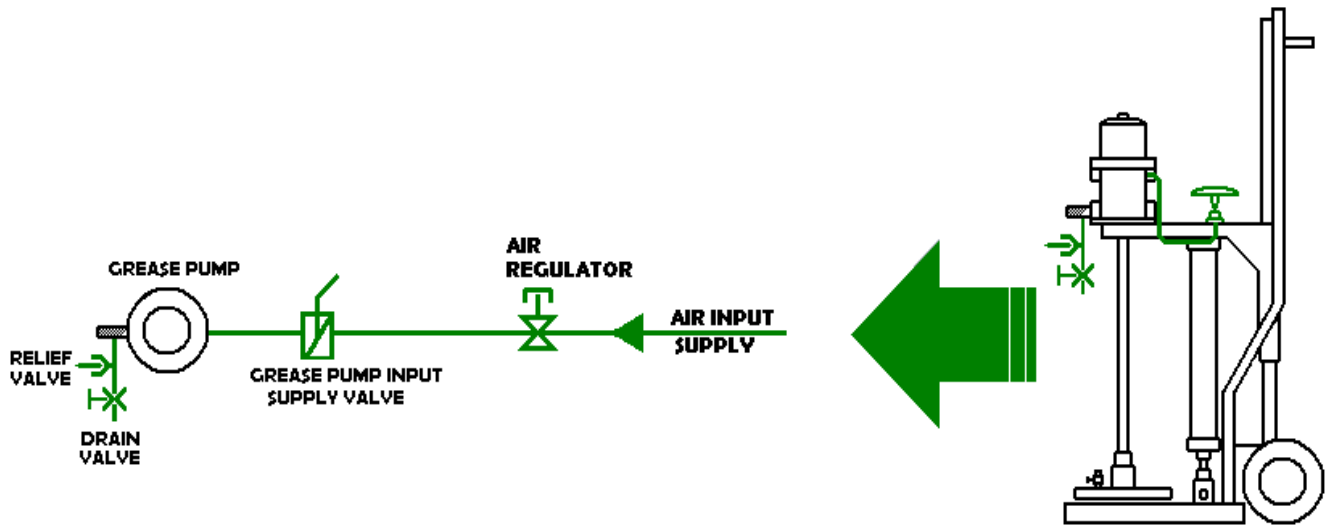

- Piston's Operational Diagram

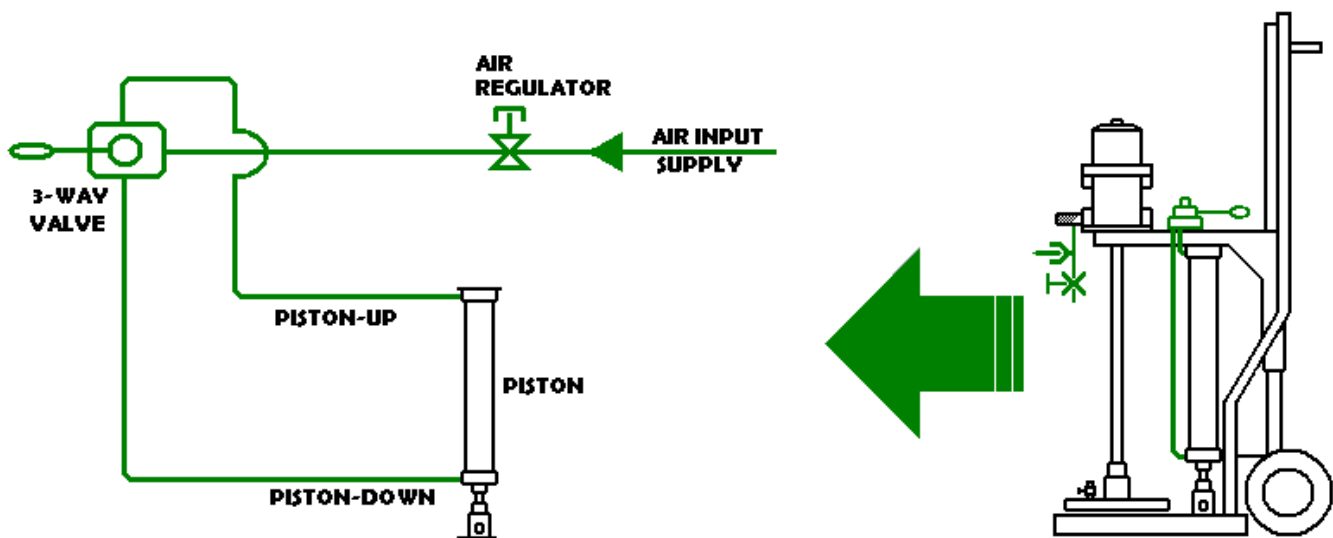

- Grease Drum Release Operational Diagram

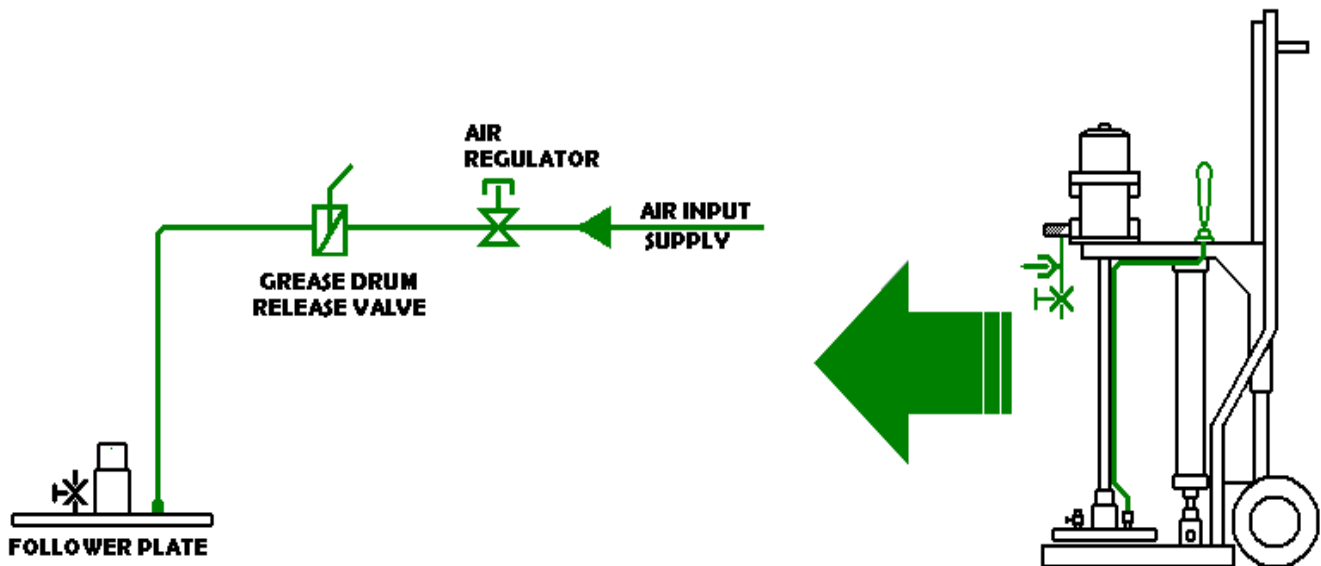

Sealweld SuperSeal II

Air Operated Pump

- OPERATION AND MAINTENANCE
- SERVICE MAINTENANCE
- OPTIONAL HAND GREASE GUN



OPERATING INSTRUCTION FOR AIR OPERATED SUPERSEAL II PUMP

NOTE: The SuperSeal II pump has a 100:1 ratio and a maximum working pressure of 10,000 psi and requires 100 psi air inlet (40CFM) connection, depending on outlet pressure required.

IMPORTANT: BEFORE THE AIR IS ATTACHED TO THE PUMP THE THREE-WAY DIRECTIONAL VALVE MUST BE IN THE CENTER POSITION AND ALL VALVES ARE CLOSED.

1. Connect the air inlet hose to the pump and set the air inlet regulator to maximum 140 psi.
2. Adjust the air inlet regulator for the three-way directional valve (Piston Control Gear) then move the handle on to the **forward** position (this lifts the air motor pump tube and the follower plate.)
3. Remove lid from 40 lb pail of lubricant/sealant and place in position (center) under follower plate.
4. Keep the drain valve close located on the follower plate.
5. Move the handle on the three-way directional valve to the **back** position (this relieves the air pressure from the top of air cylinders and directs it to the bottom of the cylinder). The follower plate will then lower into the pail.
6. Leave the three-way directional valve in the **back** position (this forces the follower plate down onto the lubricant to assist pumping).
7. Pull the grease pump input supply valve (pump will start) and purge the pump through the outlet connection. Use a purge tee and valve if possible. Push the valve to Turn off pump.
8. Connect the outlet hose, whip ball valve and purge this also. Connect whip to the valve and turn on the air motor when ready to start pumping.



NOTE: If the pail becomes empty before lubrication of a valve is complete, follow instructions 9-11 below to change pail. When new pail is in position, return to instruction 3-8 to continue pumping.

To calculate the amount of lubricant/sealant being injected into the valve, Count 40 strokes of the pump = 1 lb. Refer to the product quantity guide tables for any particular type and size of valve.

TO DE-COMMISSION THE PUMP

9. Following completion of injection, the pump (air motor) is turned off. Bleed off the injection hose (whip) from the needle valve or purge valve. Move the three-way directional valve to the **forward** position (this raises the pump follower plate with 40 lb pail attached).
10. Allow pail to be raised sufficiently and move the three-way directional valve to the **center** position.
11. Keep clear of the pail. Slowly open the grease drum release valve (this directs the air to the follower plate and will blow the empty pail off the plate).
12. Depressurise (check gauges) and disconnect whip, hoses. Close all ball valves.
13. Clean follower plate, replace dust covers, lids, end protectors etc.
14. To remove the pump from site, lower follower plate to travel position and then confirm the three-way valve is in the **center** position and disconnect the air line.

IMPORTANT: THE THREE-WAY VALVE SHOULD BE IN THE CENTER POSITION WHENEVER THE PUMP IS NOT IN USE



SERVICE MAINTENANCE FOR THE AIR OPERATED SUPERSEAL II PUMP

NOTE: To obtain maximum service life from the 9649L Bucket Lubrication unit, it is **important** to clean & maintain this unit at interval as suggested in the following:

HOUSING: Store lubrication unit in a cabinet, workshop or a canvas cover over the unit to keep it clean from extremely dusty sand or salty areas.

After a week of service work, clean the unit down and lightly lubricate the square tube slide and the follower plate is covered from letting dirt on the bottom plate.

WARNING: Do not clean Poly Carbonate air gauge with the flush. Whip and cabinet gauge are OK as these are glass.

AIR MOTOR: Keep an eye on the filter, regulator. Open the filter and drain when required. Air pressure not to exceed 100 psi..

SPARE PARTS: To obtain any spare parts or components contact Sealweld Corporation. Phone: +1 403 236 0043, Fax: +1 403 236 5487

WHIP HOSE

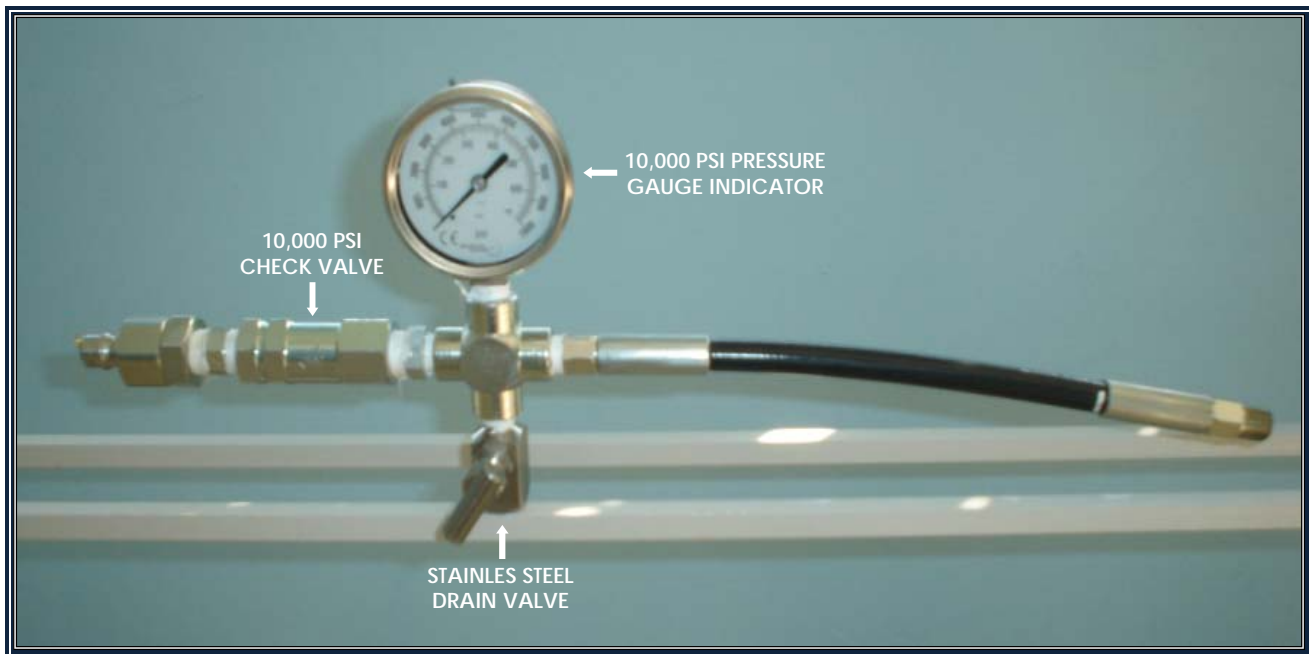

- Once the greasing job is completed and still there is pressure on the gauge after closing the drain valve, expect that the grease fitting is damaged or leaking. If this happen, disconnect the whip hose from the main hose's easy connector and leave it connected with the grease fitting. The WHIP HOSE will temporary contains the leak and holds the pressure.
- The heavy duty whip hose is equipped with 10,000 psi Check Valve, 10,000 psi Gauge Indicator and a Drain Valve for safety purposes. For this the Whip Hose can be disconnected and replace damaged fitting once the pipeline is shutdown.



Contact Information

Sealweld Corporation

#106, 4116 – 64th Ave. S.E.

Calgary Alberta

T2C 2B3

Canada

Phone: +1 403 236 0043

Fax: +1 403 236 5487

E-Mail: info@sealweld.com